

NATURE CLEAR
GWS10 DIVERSION
INSTRUCTION MANUAL

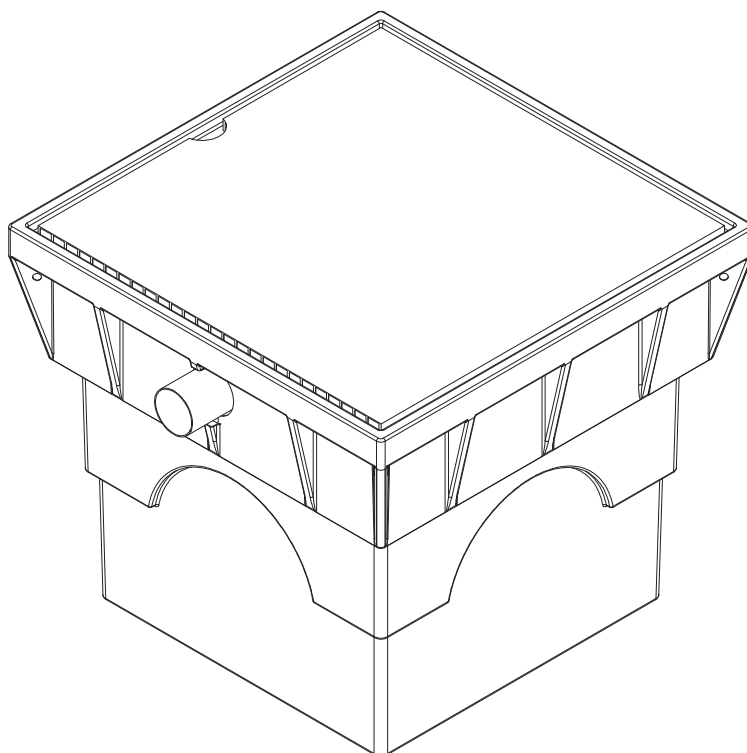

TABLE OF CONTENTS

SPECIFICATIONS	1
ABOUT THE GWS10 DIVERSION	2
GREASE TRAP OPTIONS	3
ADDITIONAL ITEMS (NOT INCLUDED)	3
GWS10 IRRIGATION SYSTEM INSTALLATION	3
GWS10 DIVERSION - GRAVITY	4
GWS10 DIVERSION - PUMPWELL	5
GREYWATER SCHEMATICS	6
MAINTENANCE	7
TROUBLESHOOTING	7

SPECIFICATIONS

TREATMENT	Primary
MATERIAL	Medium density grade polyethylene
PROPERTIES	U.V stabilised - High stress resistance
THICKNESS	Average 5 mm
CONSTRUCTION	<ul style="list-style-type: none"> - Rotational moulding - All surfaces are continuous with no welded or joined seams - Ribbed structure for additional strength
DIMENSIONS	Height: 935 mm Length: 1090 mm Width: 1090 mm
INLET SIZE	100mm DWV
OUTLET SIZE (DIVERSION)	100mm DWV
FILTER CLEANING	Manual
MEDIA	Plastic bio balls
FILTER MATERIAL	Polypropylene, staple fibre, needle-punched, non-woven geotextile
GRAVITY OPTION	Slotted drain outlet to 50mm DWV
OPTIONAL ITEMS	
ANCHOR KIT	Anti Flotation Anchor kit
PUMP	Pumpwell with pump 32mm outlet pipe 150 watt
IRRIGATION	Subsoil

ABOUT THE GWS10 DIVERSION

The GWS10 (GWS10) provides a simple and cost effective means of primary treating greywater for irrigation. On a suitable site, the only significant excavation work required to install the system will be the trenching. The ongoing costs of the GWS10 are minimal.

In order for the filtration tank to work effectively, it is necessary to remove oil and grease from the kitchen waste water. For this purpose, Ecoflo can supply a grease trap (see illustrations on next page).

The GWS10 is filled with bio balls which provides powerful biological filtration, the process of using beneficial bacteria to clean the water on a molecular level. Bio balls have been designed to provide as much surface area as possible for nitrifying bacteria to cling to, breaking down dangerous ammonia, converting them to nitrites, and then the nitrites to the less toxic nitrates. A filter cloth is laid on top of the bio balls to remove large waste particles such as hair or food scraps from getting clogged in the bio balls.

There are two models of the GWS10, the GWS10 Standard and the GWS10 PumpWell. If your distribution area is downhill from the filtration tank your geotech engineer will be able to design a distribution system without the use of a pump. If this is not the case, you will need the GWS10 Pump Well, which has an electrical submersible pump that can pump water to higher locations and irrigation beds.

After the filtration process, the water is classified as having undergone “primary treatment”. However since there is no disinfection process, most authorities will not allow the water to be disposed of above ground (e.g. via sprinkler systems), to reduce the risk of human contact. The water may be distributed via a subsurface drip irrigation system. Water may also be disposed into absorption trenches as specified by your engineer/plumber. Make sure their size calculation does not include an allowance for toilet water, which would make the trenches unnecessarily large and expensive.

Bio balls

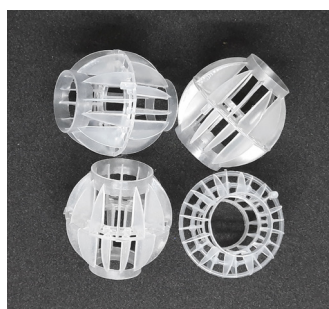

GREASE TRAP OPTIONS

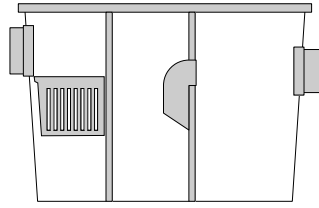

80L Grease trap

ADDITIONAL ITEMS (NOT INCLUDED)



250L/450L/600L Collection well

The collection well can collect and store any water that overflows from the GWS10 tank, ready for safe disposal at a later time (no longer than 48 hours).



Grey Flow Rotor Valve (6 stations)

For large trench systems, gardens or orchards, the G-flow helps to distribute water evenly to separate areas.



Grey Flow Drip kit

Design for both sub-surface and sub-mulch applications, the Drip Kit contains all the components necessary to set up a greywater system simply and quickly.

GWS10 INSTALLATION

- The GWS10 should be at least partially buried (at least 500mm deep) into the ground, on a bed of sand.
- If fully buried in high water table locations ensure that the tank is filled with water immediately to avoid flotation. Consider installing anti floatation anchors. Optional anchor kit available at Ecoflo.
- The GWS10 tank should be install level.
- Connect the outflow from the grease trap (if kitchen water is being diverted into your GWS10) and other waste water sources to the inlet pipe of the GWS10.

GWS10 DIVERSION - GRAVITY

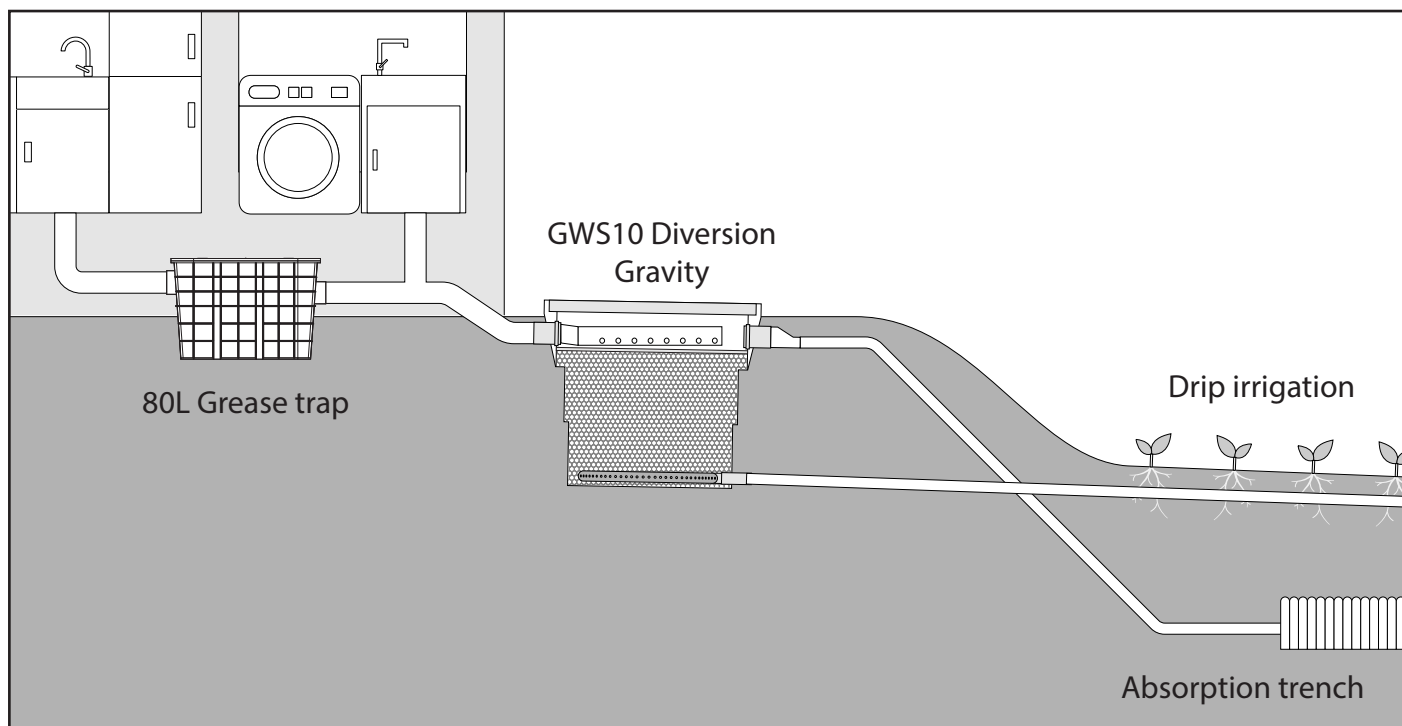
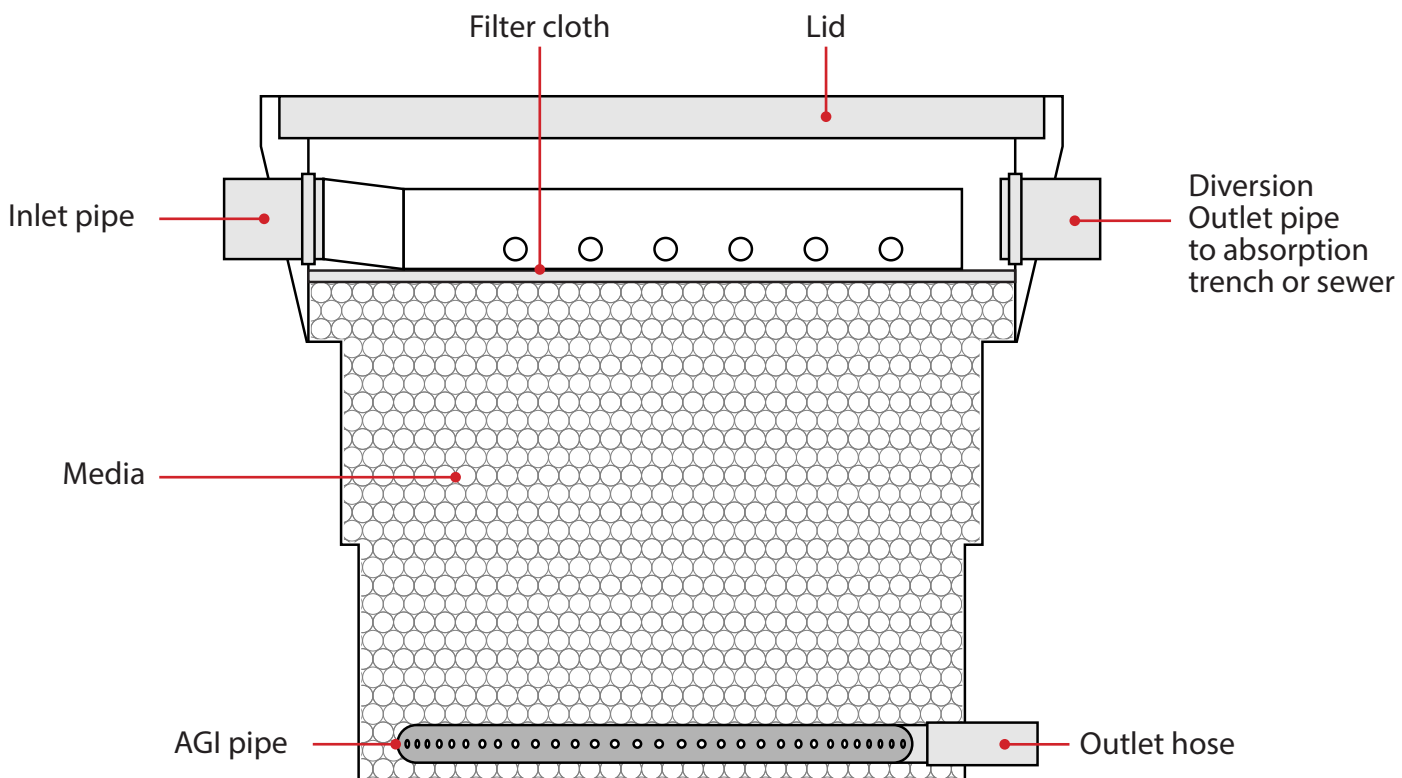

GWS10 DIVERSION - PUMPWELL

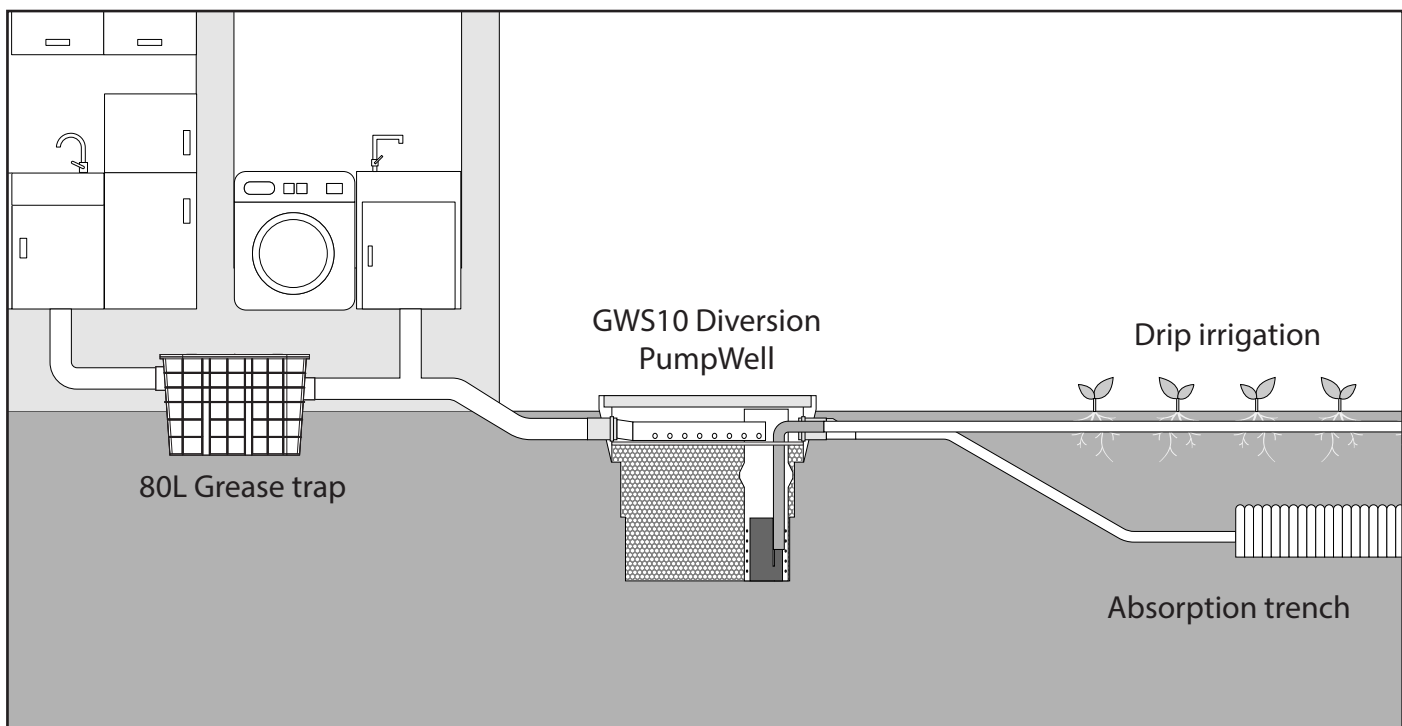
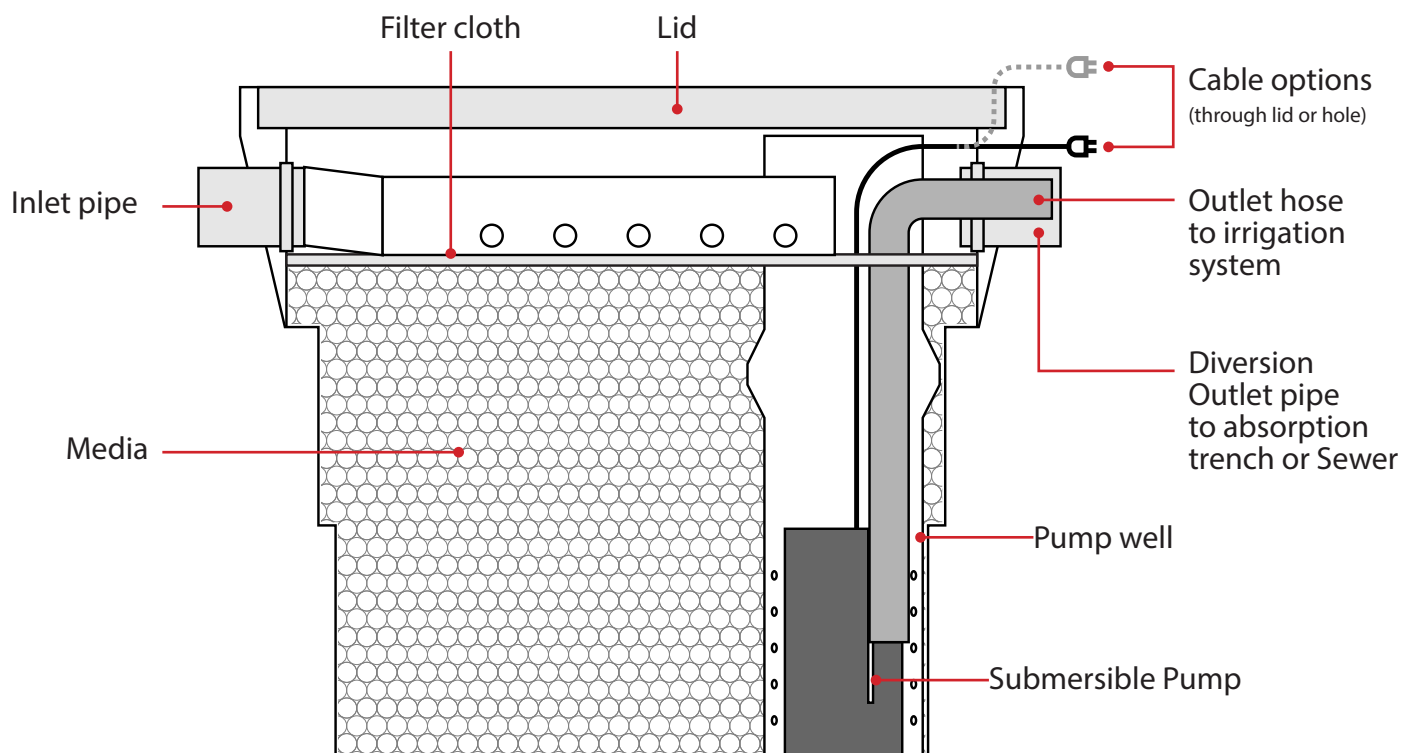

GREYWATER SCHEMATICS

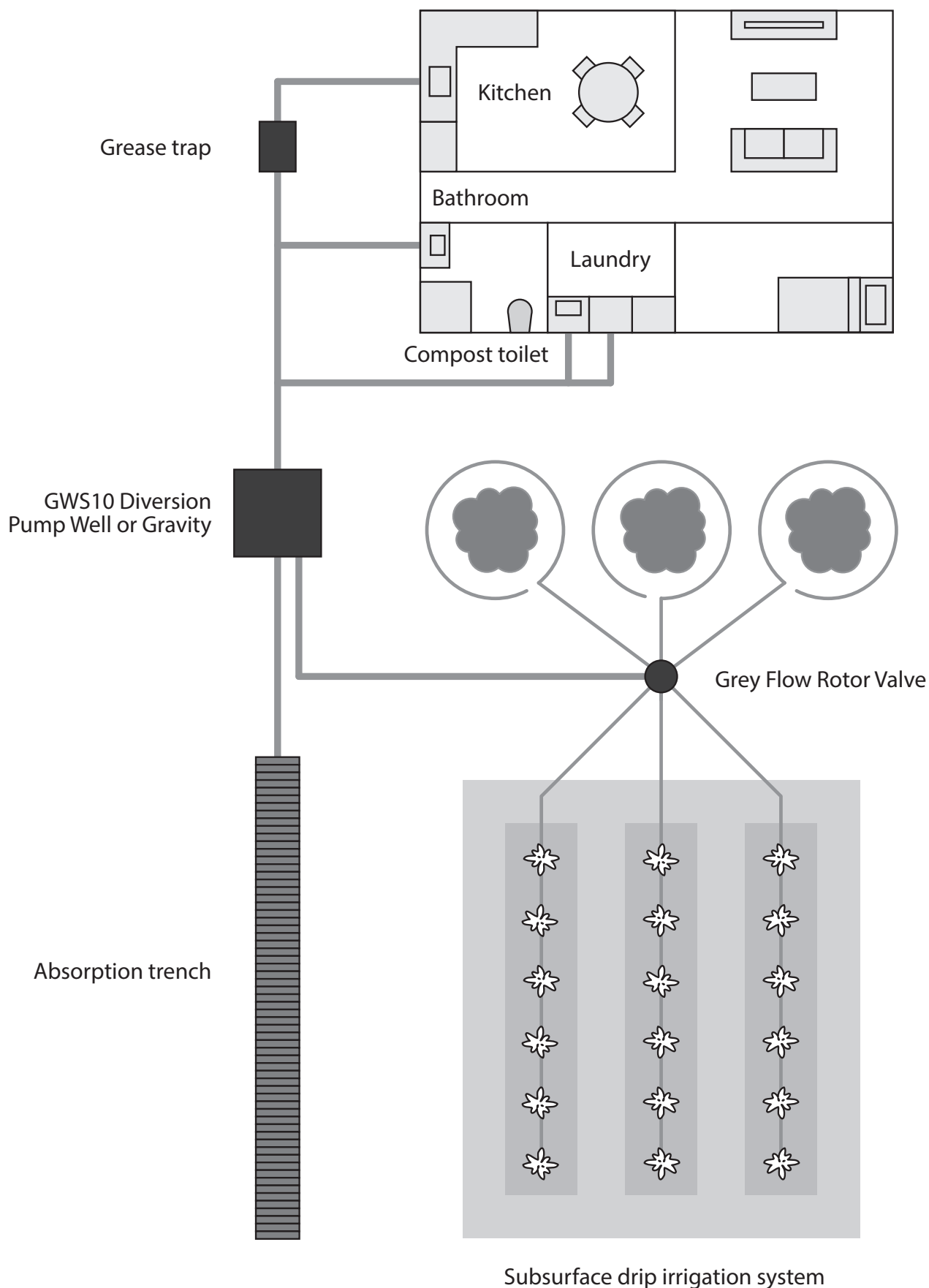

MAINTENANCE

CLEANING AGENTS:

- Use only biodegradable household cleaners for cleaning any equipment or appliance connected to the system.
- Use low phosphate and sodium detergents.
- Minimise the use of disinfectants, bleaches, whiteners and spot removers.

WASTE WATER:

- Dispose of food scraps via a compost bin or garbage collection system.
- Minimise the amount of fat deposited in the drains by wiping pans and plates with kitchen paper towels before washing.
- Put a strainer on the kitchen sink to minimise the load on the filter system.
- Do not dispose of non-liquid waste or chemicals into the drains.
- Do not use a garbage grinder.
- Ensure your grease trap is regularly cleaned out as per the supplier's recommendations.

GWS10:

- Inspect the inlet pipe for blockages on a quarterly basis. Clean if necessary.
- Every 3-6 months, inspect the filter cloth. If the filter cloth has more than 50% foreign matter, hose it into the garden bed where it will continue to compost. To remove the filter cloth, unplug the spreader pipe and remove. Contact Ecoflo if a replacement filter cloth is needed.
- Every 10 years clean out the whole tank.

TROUBLESHOOTING

If the GWS10 is draining too slowly, remove and clean the filter cloth by hosing with water. Check the outlet pipe is not blocked.

Alternatively, contact Ecoflo for a supply of Nature Flush enzyme concentrate. A daily dose of Nature Flush enzymes into the kitchen sink over a 2 week period will improve the performance of the GWS10 as the enzymes digest the grease and fat deposits which may have caused minor blockages within the system.

If water is draining too slowly from the sink, the grease trap may need emptying.

